

# Wiertła HM

---

# HW Drills

**N-POL**  
cutting tools





Nieprzelotowe wiertła do drewna z HM. Do maszyn numerycznych CNC i wiertarek. Do obróbki drewna, MDF płyt wiórowych i tworzyw sztucznych. Nacinacze negatywne skośne. bardzo dobra jakość wiercenia.



Dowel HW drills. For CNC machines and automatic drilling machines. For drilling **wood, MDF, Chipboard and plastic material.** **negative** spurs and center point, **Very good finish.**

## A106

4F

L-57



Art. nr P/RH	Art. nr L/LH	D	○/●	L	S	Price €
A106P-030	A106L-030	3	●	57	10	11,16
A106P-040	A106L-040	4	●	57	10	9,00
A106P-050	A106L-050	5	●	57	10	8,52
A106P-055	A106L-055	5.5	○	57	10	9,00
A106P-060	A106L-060	6	●	57	10	9,00
A106P-070	A106L-070	7	●	57	10	9,72
A106P-080	A106L-080	8	●	57	10	9,72
A106P-082	A106L-082	8.2	○	57	10	11,16
A106P-090	A106L-090	9	●	57	10	11,40
A106P-100	A106L-100	10	●	57	10	11,52
A106P-110	A106L-110	11	○	57	10	12,72
A106P-120	A106L-120	12	○	57	10	13,56
A106P-130	A106L-130	13	○	57	10	17,04
A106P-140	A106L-140	14	○	57	10	19,08
A106P-150	A106L-150	15	○	57	10	19,08
A106P-160	A106L-160	16	○	57	10	22,68

● - na magazynie / on stock;

○ - na zapytanie / on request

## A107

4F

L-70



Art. nr P/RH	Art. nr L/LH	D	○/●	L	S	Price €
A107P-030	A107L-030	3	●	70	10	11,88
A107P-040	A107L-040	4	●	70	10	9,48
A107P-045	A107L-045	4.5	○	70	10	9,48
A107P-050	A107L-050	5	●	70	10	9,24
A107P-055	A107L-055	5.5	○	70	10	9,48
A107P-060	A107L-060	6	●	70	10	9,48
A107P-062	A107L-062	6.2	○	70	10	10,20
A107P-065	A107L-065	6.5	○	70	10	10,20
A107P-070	A107L-070	7	●	70	10	10,20
A107P-075	A107L-075	7.5	○	70	10	10,68
A107P-080	A107L-080	8	●	70	10	10,68
A107P-082	A107L-082	8.2	○	70	10	11,76
A107P-085	A107L-085	8.5	○	70	10	11,76
A107P-090	A107L-090	9	●	70	10	11,76
A107P-095	A107L-095	9.5	○	70	10	12,00
A107P-100	A107L-100	10	●	70	10	11,88
A107P-102	A107L-102	10.2	○	70	10	13,56
A107P-105	A107L-105	10.5	○	70	10	13,56
A107P-110	A107L-110	11	●	70	10	13,56
A107P-120	A107L-120	12	●	70	10	14,04
A107P-130	A107L-130	13	○	70	10	17,76
A107P-140	A107L-140	14	●	70	10	19,68
A107P-150	A107L-150	15	●	70	10	19,92
A107P-160	A107L-160	16	○	70	10	23,76

 Nieprzelotowe wiertła do drewna z HM. Do maszyn numerycznych CNC i wiertarek. Do obróbki drewna, MDF płyt wiórowych i tworzyw sztucznych. Nacinacze negatywne skośne. bardzo dobra jakość wiercenia.

 Dowel HW drills. For CNC machines and automatic drilling machines. For drilling wood, MDF, Chipboard and plastic material. negative spurs and center point, Very good finish.

Art. nr P/RH	Art. nr L/LH	D	○/●	L	S	Price €
A108P-050	A108L-050	5	●	77	10	9,36
A108P-055	A108L-055	5.5	○	77	10	10,32
A1080-060	A108L-060	6	●	77	10	10,32
A1080-070	A108L-070	7	●	77	10	11,28
A108P-080	A108L-080	8	●	77	10	12,00
A108P-082	A108L-082	8,2	○	77	10	12,72
A108P-100	A108L-100	10	●	77	10	12,96
A108P-120	A108L-120	12	○	77	10	15,36
A108P-140	A108L-140	14	○	77	10	21,36

● - na magazynie / on stock; ○ - na zapytanie / on request

## A108

4F L-77



www.npol.com.pl

Art. nr P/RH	Art. nr L/LH	D	○/●	L	S	Price €
A109P-050	A109L-050	5	●	85	10	10,56
A109P-060	A109L-060	6	●	85	10	11,28
A109P-070	A109L-070	7	●	85	10	12,00
A109P-080	A109L-080	8	●	85	10	12,00
A109P-090	A109L-090	9	●	85	10	14,16
A109P-100	A109L-100	10	●	85	10	14,16
A109P-120	A109L-120	12	●	85	10	16,80
A109P-140	A109L-140	14	○	85	10	23,76
A109P-150	A109L-150	15	○	85	10	25,44
A109P-160	A109L-160	16	○	85	10	27,60

● - na magazynie / on stock; ○ - na zapytanie / on request

## A109

4F

L-85



Art. nr P/RH	Art. nr L/LH	D	○/●	L	S	Price €
A110P-050	A110L-050	5	●	105	10	11,04
A110P-060	A110L-060	6	●	105	10	12,00
A110P-070	A110L-070	7	○	105	10	12,96
A110P-080	A110L-080	8	●	105	10	12,96
A110P-090	A110L-090	9	○	105	10	15,12
A110P-100	A110L-100	10	●	105	10	15,12
A110P-110	A110L-110	11	○	105	10	16,56
A110P-120	A110L-120	12	●	105	10	17,52
A110P-130	A110L-130	13	○	105	10	21,36
A110P-140	A110L-140	14	○	105	10	25,68
A110P-160	A110L-160	16	○	105	10	30,00

● - na magazynie / on stock; ○ - na zapytanie / on request

## A110

4F

L-105





Przelotowe wiertła do drewna z HM. Do maszyn numerycznych CNC i wiertarek. Do obróbki drewna, MDF płyt wiórowych i tworzyw sztucznych. Nacinacze negatywne skośne. bardzo dobra jakość wiercenia.



Through hole HW drills. For CNC machines and automatic drilling machines. For drilling wood, MDF, Chipboard and plastic material. negative spurs and center point, Very good finish.

## A201



L-57

4F



Art. nr P/RH	Art. nr L/LH	D	o/•	L	S	Price €
A201P-030	A201L-030	3	•	57	10	11,52
A201P-040	A201L-040	4	•	57	10	9,36
A201P-050	A201L-050	5	•	57	10	9,36
A201P-060	A201L-060	6	•	57	10	9,60
A201P-070	A201L-070	7	•	57	10	10,08
A201P-080	A201L-080	8	•	57	10	10,32
A201P-082	A201L-082	8,2	o	57	10	11,76
A201P-090	A201L-090	9	o	57	10	11,76
A201P-100	A201L-100	10	•	57	10	11,76
A201P-105	A201L-105	10,5	o	57	10	13,92
A201P-120	A201L-120	12	o	57	10	14,16
A201P-140	A201L-140	14	o	57	10	19,68

• - na magazynie / on stock;

o - na zapytanie / on request

## A202



L-70

4F



Art. nr P/RH	Art. nr L/LH	D	o/•	L	S	Price €
A202P-030	A202L-030	3	•	70	10	12,24
A202P-040	A202L-040	4	•	70	10	9,36
A202P-045	A202L-045	4.5	o	70	10	9,84
A202P-050	A202L-050	5	•	70	10	9,60
A202P-055	A202L-055	5.5	o	70	10	9,84
A202P-060	A202L-060	6	•	70	10	9,60
A202P-065	A202L-065	6.5	o	70	10	10,32
A202P-070	A202L-070	7	•	70	10	10,32
A202P-075	A202L-075	7.5	o	70	10	12,00
A202P-080	A202L-080	8	•	70	10	12,24
A202P-085	A202L-085	8.5	o	70	10	12,72
A202P-090	A202L-090	9	•	70	10	12,72
A202P-100	A202L-100	10	•	70	10	12,72
A202P-105	A202L-105	10.5	o	70	10	14,40
A202P-110	A202L-110	11	o	70	10	14,40
A202P-120	A202L-120	12	•	70	10	14,88
A202P-130	A202L-130	13	o	70	10	15,36
A202P-140	A202L-140	14	o	70	10	18,00
A202P-150	A202L-150	15	o	70	10	20,16

• - na magazynie / on stock;

o - na zapytanie / on request

 Przelotowe wiertła do drewna z HM. Do maszyn numerycznych CNC i wiertarek. Do obróbki drewna, MDF płyt wiórowych i tworzyw sztucznych. Nacinacze negatywne skośne. bardzo dobra jakość wiercenia.

 Through hole HW drills. For CNC machines and automatic drilling machines. For drilling wood, MDF, Chipboard and plastic material. negative spurs and center point, Very good finish.

Art. nr P/RH	Art. nr L/LH	D	○/●	L	S	Price €
A203P-040	A203L-040	4	●	77	10	11,28
A203P-045	A203L-045	4,5	○	77	10	11,28
A203P-050	A203L-050	5	●	77	10	10,80
A203P-055	A203L-055	5,5	○	77	10	11,52
A2030-060	A203L-060	6	●	77	10	11,04
A2030-070	A203L-070	7	●	77	10	12,24
A203P-080	A203L-080	8	●	77	10	12,24
A203P-090	A203L-090	9	●	77	10	13,92
A203P-100	A203L-100	10	●	77	10	14,88
A203P-110	A203L-110	11	○	77	10	16,08
A203P-120	A203L-120	12	○	77	10	17,04

● - na magazynie / on stock; ○ - na zapytanie / on request

## A203

### L-77



www.npol.com.pl

Art. nr P/RH	Art. nr L/LH	D	○/●	L	S	Price €
A204P-050	A204L-050	5	●	85	10	11,76
A204P-055	A204L-055	5,5	○	85	10	11,76
A2040-060	A204L-060	6	●	85	10	12,24
A2040-070	A204L-070	7	●	85	10	13,20
A204P-080	A204L-080	8	●	85	10	13,20
A204P-090	A204L-090	9	●	85	10	15,12
A204P-100	A204L-100	10	●	85	10	16,32
A204P-110	A204L-110	11	●	85	10	17,28
A204P-120	A204L-120	12	●	85	10	18,00
A204P-130	A204L-130	13	○	85	10	19,68
A204P-140	A204L-140	14	○	85	10	22,80
A204P-150	A204L-150	15	○	85	10	25,92

● - na magazynie / on stock; ○ - na zapytanie / on request

## A204

### L-85



Art. nr P/RH	Art. nr L/LH	D	○/●	L	S	Price €
A205P-050	A205L-050	5	●	105	10	12,96
A205P-060	A205L-060	6	●	105	10	14,16
A205P-070	A205L-070	7	●	105	10	15,12
A205P-080	A205L-080	8	●	105	10	15,12
A205P-090	A205L-090	9	●	105	10	17,28
A205P-100	A205L-100	10	●	105	10	18,48
A205P-110	A205L-110	11	○	105	10	20,16
A205P-120	A205L-120	12	●	105	10	20,64
A205P-130	A205L-130	13	○	105	10	22,56
A205P-140	A205L-140	14	○	105	10	25,68
A205P-150	A205L-150	15	○	105	10	29,52

● - na magazynie / on stock; ○ - na zapytanie / on request

## A205

### L-105







Wiertła puszkowe do drewna z HM Z=2+2. Do maszyn numerycznych CNC i wiertarek. Do obróbki drewna, MDF płyt wiórowych i tworzyw sztucznych. 2 nacinacze negatywne skośne. bardzo dobra jakość wiercenia.



HW hinge boring bits Z=2+2. For CNC machines and automatic drilling machines. For drilling wood, MDF, Chipboard and plastic material. Very good finish.

## A301

L-57

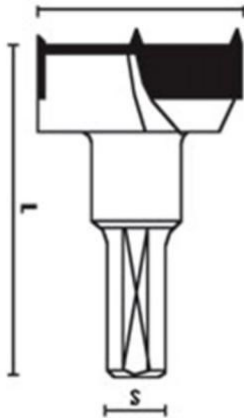

Art. nr P/RH	Art. nr L/LH	D	○/●	L	S	Price €
A301P-150	A301L-150	15	●	57	10	12,72
A301P-160	A301L-160	16	○	57	10	12,96
A301P-170	A301L-170	17	○	57	10	13,44
A301P-180	A301L-180	18	●	57	10	13,44
A301P-190	A301L-190	19	○	57	10	13,20
A301P-200	A301L-200	20	●	57	10	13,20
A301P-220	A301L-220	22	●	57	10	14,40
A301P-240	A301L-240	24	○	57	10	14,40
A301P-250	A301L-250	25	●	57	10	14,40
A301P-260	A301L-260	26	●	57	10	16,08
A301P-280	A301L-280	28	○	57	10	16,08
A301P-300	A301L-300	30	●	57	10	17,28
A301P-320	A301L-320	32	○	57	10	17,76
A301P-340	A301L-340	34	○	57	10	19,20
A301P-350	A301L-350	35	●	57	10	19,20
A301P-380	A301L-380	38	○	57	10	23,76
A301P-400	A301L-400	40	○	57	10	25,44

● - na magazynie / on stock;

○ - na zapytanie / on request

## A302

L-70

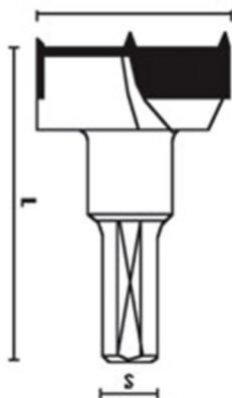



Art. nr P/RH	Art. nr L/LH	D	○/●	L	S	Price €
A302P-150	A302L-150	15	●	70	10	13,20
A302P-160	A302L-160	16	●	70	10	13,68
A302P-170	A302L-170	17	○	70	10	13,92
A302P-180	A302L-180	18	●	70	10	13,92
A302P-190	A302L-190	19	○	70	10	14,40
A302P-200	A302L-200	20	●	70	10	14,16
A302P-220	A302L-220	22	●	70	10	14,40
A302P-240	A302L-240	24	○	70	10	15,12
A302P-250	A302L-250	25	●	70	10	15,12
A302P-260	A302L-260	26	○	70	10	15,60
A302P-280	A302L-280	28	○	70	10	16,32
A302P-300	A302L-300	30	●	70	10	18,00
A302P-320	A302L-320	32	○	70	10	18,48
A302P-340	A302L-340	34	○	70	10	19,92
A302P-350	A302L-350	35	●	70	10	20,16
A302P-380	A302L-380	38	○	70	10	25,20
A302P-400	A302L-400	40	○	70	10	27,60

● - na magazynie / on stock;

○ - na zapytanie / on request

L-90 pod zamówienie / on request

 Pełno węgliskowe, nieprzelotowe wiertła do drewna. Do maszyn numerycznych CNC i wiertarek. Do obróbki drewna, MDF płyt wiórowych i tworzyw sztucznych. Półokrągłe nacinacze. Bardzo dobra jakość wiercenia.

 Solid carbide dowell drill bits. For CNC machines and automatic drilling machines . For drilling **wood, MDF, Chipboard and plastic material. Excelent finish.**

Art. nr P/RH	Art. nr L/LH	D	○/●	L	S	Price €
A401P-030	A401L-030	3	○	57	10	13,20
A401P-040	A401L-040	4	○	57	10	14,40
A401P-050	A401L-050	5	●	57	10	16,08
A401P-060	A401L-060	6	○	57	10	18,48
A401P-070	A401L-070	7	○	57	10	23,28
A401P-080	A401L-080	8	●	57	10	24,00
A401P-090	A401L-090	9	○	57	10	30,96
A401P-100	A401L-100	10	○	57	10	32,40

VHM L-57

A401



Art. nr P/RH	Art. nr L/LH	D	○/●	L	S	Price €
A402P-030	A402L-030	3	○	70	10	14,40
A402P-040	A402L-040	4	○	70	10	16,56
A402P-050	A402L-050	5	●	70	10	18,72
A402P-060	A402L-060	6	●	70	10	21,60
A402P-070	A402L-070	7	○	70	10	27,12
A402P-080	A402L-080	8	●	70	10	28,56
A402P-090	A402L-090	9	○	70	10	34,80
A402P-100	A402L-100	10	○	70	10	38,40

VHM L-70

A402



● - na magazynie / on stock; ○ - na zapytanie / on request

 Pełno węgliskowe wiertła przelotowe do drewna. Do maszyn numerycznych CNC i wiertarek. Do obróbki drewna, MDF płyt wiórowych i tworzyw sztucznych. Bardzo dobra jakość wiercenia i żywotność.

 Solid carbide through hole drill bits. For CNC machines and automatic drilling machines . For drilling **wood, MDF, Chipboard and plastic material. Excelent finish.**

Art. nr P/RH	Art. nr L/LH	D	○/●	L	S	Price €
A403P-030	A403L-030	3	○	57	10	13,92
A403P-040	A403L-040	4	○	57	10	16,08
A403P-050	A403L-050	5	●	57	10	16,80
A403P-060	A403L-060	6	○	57	10	19,20
A403P-070	A403L-070	7	○	57	10	24,48
A403P-080	A403L-080	8	●	57	10	25,68
A403P-090	A403L-090	9	○	57	10	32,88
A403P-100	A403L-100	10	○	57	10	35,28

VHM L-57

A403



Art. nr P/RH	Art. nr L/LH	D	○/●	L	S	Price €
A404P-030	A404L-030	3	○	70	10	15,12
A404P-040	A404L-040	4	○	70	10	17,28
A404P-050	A404L-050	5	●	70	10	19,44
A404P-060	A404L-060	6	●	70	10	23,04
A404P-070	A404L-070	7	●	70	10	28,80
A404P-080	A404L-080	8	●	70	10	30,72
A404P-090	A404L-090	9	○	70	10	36,72
A404P-100	A404L-100	10	○	70	10	39,84

VHM L-70

A404





Nieprzelotowe wiertła do drewna z HM wersja HP. Do maszyn numerycznych CNC i wiertarek. Do obróbki drewna, MDF płyt wiórowych i tworzyw sztucznych. Nacinacze negatywne skośne. bardzo dobra jakość wiercenia.



Dowel HW drills type HP. For CNC machines and automatic drilling machines. For drilling **wood, MDF, Chipboard and plastic material.** **negative** spurs and center point, **Very good finish.**

### A501 HP L-57



Art. nr P/RH	Art. nr L/LH	D	o/●	L	S	Price €
A501P-040	A501L-040	4	○	57	10	13,20
A501P-050	A501L-050	5	●	57	10	12,72
A501P-060	A501L-060	6	○	57	10	13,44
A501P-070	A501L-070	7	○	57	10	14,88
A501P-080	A501L-080	8	●	57	10	14,16
A501P-100	A501L-100	10	●	57	10	17,76
A501P-120	A501L-120	12	○	57	10	20,40

### A502 HP L-70

Art. nr P/RH	Art. nr L/LH	D	o/●	L	S	Price €
A502P-040	A502L-040	4	○	70	10	13,44
A502P-050	A502L-050	5	●	70	10	12,96
A502P-060	A502L-060	6	○	70	10	13,68
A502P-070	A502L-070	7	○	70	10	14,88
A502P-080	A502L-080	8	●	70	10	14,88
A502P-100	A502L-100	10	●	70	10	18,48
A502P-120	A502L-120	12	○	70	10	20,88

● - na magazynie / on stock; ○ - na zapytanie / on request



Przelotowe wiertła do drewna z HM wersja HP. Do maszyn numerycznych CNC i wiertarek. Do obróbki drewna, MDF płyt wiórowych i tworzyw sztucznych. Bardzo dobra jakość wiercenia.



Through hole HW drills type HP. For CNC machines and automatic drilling machines. For drilling **wood, MDF, Chipboard and plastic material.** **Very good finish.**

### A601 HP L-57



Art. nr P/RH	Art. nr L/LH	D	o/●	L	S	Price €
A601P-040	A601L-040	4	○	57	10	13,20
A601P-050	A601L-050	5	●	57	10	12,96
A601P-060	A601L-060	6	○	57	10	13,44
A601P-070	A601L-070	7	○	57	10	14,88
A601P-080	A601L-080	8	●	57	10	14,16
A601P-100	A601L-100	10	●	57	10	17,76
A601P-120	A601L-120	12	○	57	10	20,40

● - na magazynie / on stock; ○ - na zapytanie / on request

### A602 HP L-70

Art. nr P/RH	Art. nr L/LH	D	o/●	L	S	Price €
A602P-040	A602L-040	4	○	70	10	13,44
A602P-050	A602L-050	5	●	70	10	12,96
A602P-060	A602L-060	6	○	70	10	13,68
A602P-070	A602L-070	7	○	70	10	15,12
A602P-080	A602L-080	8	●	70	10	14,28
A602P-100	A602L-100	10	●	70	10	18,72
A602P-120	A602L-120	12	○	70	10	20,88



 Wiertła puszkowe do drewna z vHM Z=2. Do maszyn numerycznych CNC i wiertarek. Do obróbki drewna, MDF płyt wiórowych i tworzyw sztucznych. 2 nacinacze półokrągłe. Bardzo dobra jakość wiercenia.

 VHW hinge boring bits Z=2+2. For CNC machines and automatic drilling machines . For drilling **wood, MDF, Chipboard and plastic material. Very good finish.**

Art. nr P/RH	Art. nr L/LH	D	○/●	L	S	Price €
A604P-150	A604L-150	15	○	57	10x25	20,40
A604P-200	A604L-200	20	○	57	10x25	25,92
A604P-250	A604L-250	25	○	57	10x25	28,80
A604P-300	A604L-300	30	○	57	10x25	34,80
A604P-350	A604L-350	35	○	57	10x25	44,40

## A604

VHM **HP 57**



Art. nr P/RH	Art. nr L/LH	D	○/●	L	S	Price €
A605P-150	A605L-150	15	●	70	10x25	€ 19,44
A605P-200	A605L-200	20	○	70	10x25	€ 25,20
A605P-250	A605L-250	25	●	70	10x25	€ 28,08
A605P-300	A605L-300	30	○	70	10x25	€ 33,60
A605P-350	A605L-350	35	●	70	10x25	€ 42,96

## A605

VHM **HP 70**



● - na magazynie / on stock; ○ - na zapytanie / on request

 Pogłębiacze skośne do wiertel Z=2. Do maszyn numerycznych CNC i wiertarek. Do obróbki drewna, MDF płyt wiórowych i tworzyw sztucznych. Bardzo dobra jakość wiercenia.

 HW countersinks Z=2 for drills. For CNC machines and automatic drilling machines . For drilling **wood, MDF, Chipboard and plastic material. Very good finish.**



Art. nr P/RH	Art. nr L/LH	d	L	S	Price €
A665-01 HM	A665-02 HM	3	60	10x30	€ 46,80
A665-03 HM	A665-04 HM	4	60	10x30	€ 46,80
A665-05 HM	A665-06 HM	5	60	10x30	€ 46,80

## A665 HM

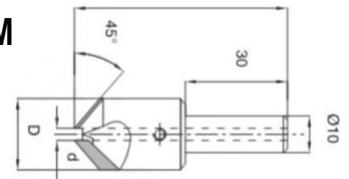

Art. nr P/RH	Art. nr L/LH	d	D	Price €
A698-01	A698-02	4	16	€ 16,56
A698-03	A698-04	5	16	€ 16,56
A698-05	A698-06	6	16	€ 16,56
A698-07	A698-08	7	16	€ 16,56
A698-09	A698-10	8	16	€ 16,56
A698-11	A698-12	9	18	€ 16,56
A698-13	A698-14	10	20	€ 16,56
A698-15	A698-16	11	20	€ 16,56
A698-17	A698-18	12	20	€ 16,56

## A698

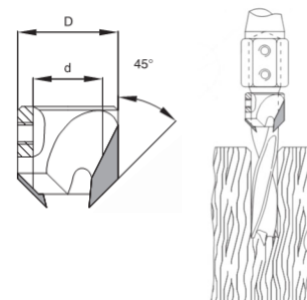



Pogłębiacze proste do wiertel Z=2. Do maszyn numerycznych CNC i wiertarek. Do obróbki drewna, MDF płyt wiórowych i tworzyw sztucznych. Bardzo dobra jakość wiercenia.



HW straight countersinks Z=2+2 for drills. For CNC machines and automatic drilling machines. For drilling wood, MDF, Chipboard and plastic material. Very good finish.

R100

Z=2+2

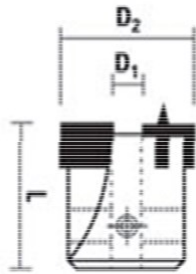

Art. nr P/RH	Art. nr L/LH	D1	D2	L	Price €
R100.050.R	R100.050.L	5	16	20	55,20
R100.060.R	R100.060.L	6	16	20	55,20
R100.061.R	R100.061.L	6	20	20	57,60
R100.070.R	R100.070.L	7	16	20	57,60
R100.080.R	R100.080.L	8	16	20	57,60
R100.081.R	R100.081.L	8	19	20	60,00
R100.082.R	R100.082.L	8	20	20	63,60
R100.090.R	R100.090.L	9	19	20	64,80
R100.091.R	R100.091.L	9	20	20	64,80
R100.100.R	R100.100.L	10	20	20	69,60
R100.101.R	R100.101.L	10	25	20	70,80
R100.102.R	R100.102.L	10	30	20	76,80
R100.120.R	R100.120.L	12	25	20	80,40
R100.121.R	R100.121.L	12	30	20	90,00

## Redukcje do wiertel/ Drill holder



Art. nr	d	D	L	Price €
Z010.020.N	2	10	24	€ 10,08
Z010.025.N	2,5	10	24	€ 10,08
Z010.030.N	3	10	24	€ 10,08
Z010.032.N	3,2	10	24	€ 10,08
Z010.035.N	3,5	10	24	€ 10,08
Z010.040.N	4	10	24	€ 10,08
Z010.045.N	4,5	10	24	€ 10,08
Z010.050.N	5	10	24	€ 10,08
Z010.060.N	6	10	24	€ 10,08

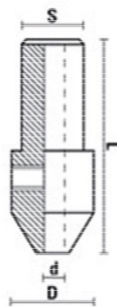

Art. nr	d	D	L	S	Price €
Z011.020.N	2	15	35	10	12,00
Z011.025.N	2,5	15	35	10	12,00
Z011.030.N	3	15	35	10	12,00
Z011.032.N	3,2	15	35	10	12,00
Z011.035.N	3,5	15	35	10	12,00
Z011.040.N	4	15	35	10	12,00
Z011.045.N	4,5	15	35	10	12,00
Z011.050.N	5	15	35	10	16,56
Z011.060.N	6	15	35	10	16,56

## UCHWYTY DO WIERTEŁ / DRILL ADAPTORS

Art. nr P/RH	Art. nr L/LH	D	d	L
L.001.080.R	L.001.080.L	15,5	8	41
L.001.100.R	L.001.100.L	19,5	10	41

Morbidelli, Biesse, Weeke

Art. nr P/RH	Art. nr L/LH	D	d	L
L.002.080.R	L.002.080.L	15,5	8	46
L.002.100.R	L.002.100.L	19,5	10	46

Vitap, Busellato, Schleicher

Art. nr P/RH	Art. nr L/LH	D	d	L
L.003.080.R	L.003.080.L	15,5	8	40
L.003.100.R	L.003.100.L	19,5	10	40

Ayen, Holzma, Mayer

Art. nr P/RH	Art. nr L/LH	D	d	L
L.004.080.R	L.004.080.L	15,5	8	41
L.004.100.R	L.004.100.L	19,5	10	41

M8 - Morbidelli, Nottmayer

Art. nr P/RH	Art. nr L/LH	D	d	L
L.005.080.R	L.005.080.L	15,5	8	40
L.005.100.R	L.005.100.L	19,5	10	40

M8 - Nottmayer

Art. nr P/RH	Art. nr L/LH	D	d	L
L.006.080.R	L.006.080.L	15,5	8	51
L.006.100.R	L.006.100.L	19,5	10	51

M8 - Bilek

Art. nr P/RH	Art. nr L/LH	D	d	L
L.030.100.R	L.030.100.L	20	10	30
L.030.101.R	L.030.101.L	20	10	37

BIESSE

Art. nr	D	d	L
L.031.100.R	20	10	43
L.031.101.R	16	10	43

Morbidelli

Art. nr	D	d	L
L.031.500.R	20	10	44

Morbidelli

Art. nr P/RH	Art. nr L/LH	D	d	L
L.031.600.R	L.031.600.L	11	M10	41

Morbidelli

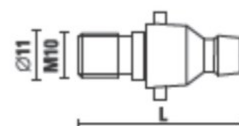
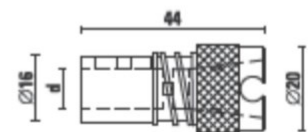
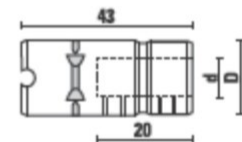
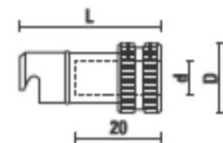
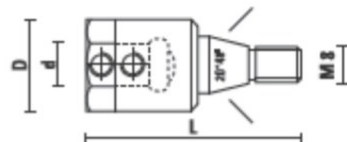
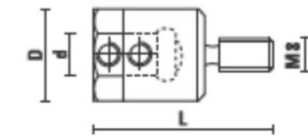
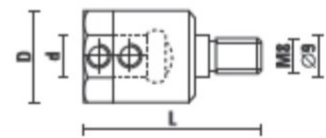
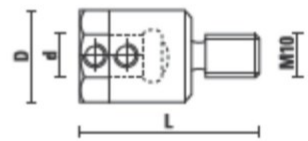
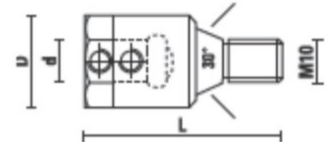
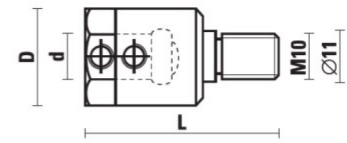

## UCHWYTY DO WIERTEŁ / DRILL ADAPTORS

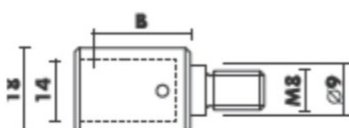
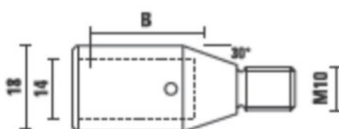
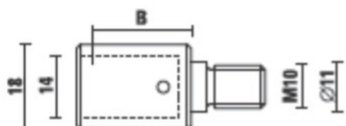
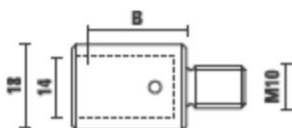
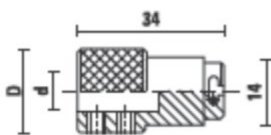
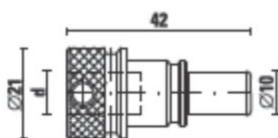
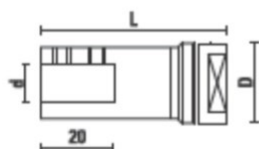
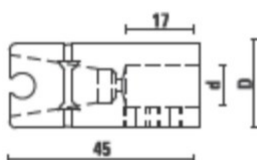
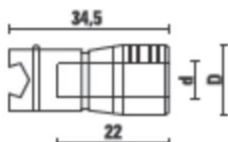
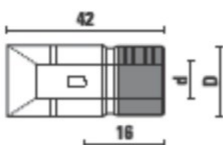
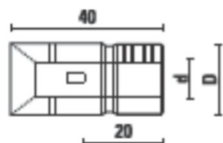

Art. nr prawe	D	d	L
L.032.100.R	20	10	40

Masterwood, Maggi, Griggio

Art. nr prawe	D	d	L
L.033.100.R	18	10	42

Vitap

Art. nr prawe	D	d	L
L.034.100.R	19	10	34,5

Busellato

Art. nr prawe	D	d	L
L.035.100.R	20	10	45

Detel

Art. nr prawe	D	d	L
L.040.100.R	20	10	46
L.040.101.R	20	10	56
L.040.102.R	20	10	66

Weeke

Art. nr prawe	D	d	L
L.060.100.N	21	10	42

Biesse

Art. nr prawe	D	d	L
L.050.100.N	18	10	34

Art. nr P/RH	Art. nr L/LH	D	d	B
L.051.100.R	L.051.100.L	18	10	22,5

Ayen, Holzma

Art. nr P/RH	Art. nr L/LH	D	d	B
L.052.100.R	L.052.100.L	18	10	22,5

Morbidelli, Biesse, Weeke, Busellato, Torwege

Art. nr P/RH	Art. nr L/LH	D	d	B
L.053.100.R	L.053.100.L	18	10	22,5

Vitap, Alberti

Art. nr P/RH	Art. nr L/LH	D	d	B
L.054.100.R	L.054.100.L	18	10	22,5

Notmayer